

SERVICE BULLETIN

Affected Park:
Affected Ride: INVERTED COASTER
Ride Name:

Item: Steel brake pad
Retaining bolts of the steel brake pad

Abstract of Issue:

Inspection of the steel brake pads and retaining bolts as per drawing on page 2.

Reason for Release:

Cracks were discovered on the second steel brake pads of the pilot coach in the transition area between chamfered and straight section.

Actions to be taken:

- visual and magnetic particle inspection of the steel brake pads in the area shown in the drawing on page 2. The Steel brakes pads presenting indications must be replaced.
- visual inspection and torque inspection of the retaining bolts.

Schedule:

Steel brake pads:

- Visual inspection: immediately.
- Magnetic particle testing: within a week.

Retaining bolts:

- Visual inspection and torque inspection.

Additional request for maintenance:

The area between chamfered and straight section of the steel brake pad shall be checked as follows:

- Visually: every month.
- magnetic particles: annually.

SERVICE BULLETIN

Inverted Coaster (pilot car)

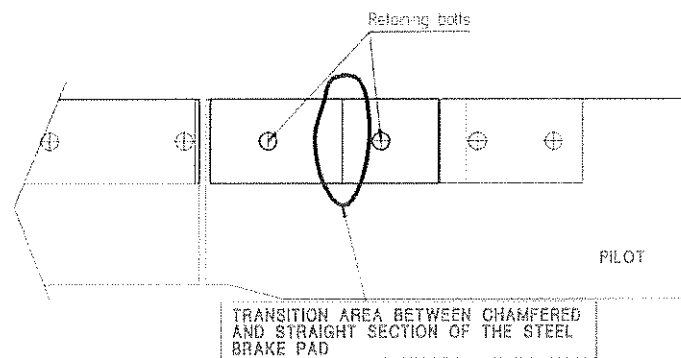

⇨ DIRECTION OF MOTION ⇨

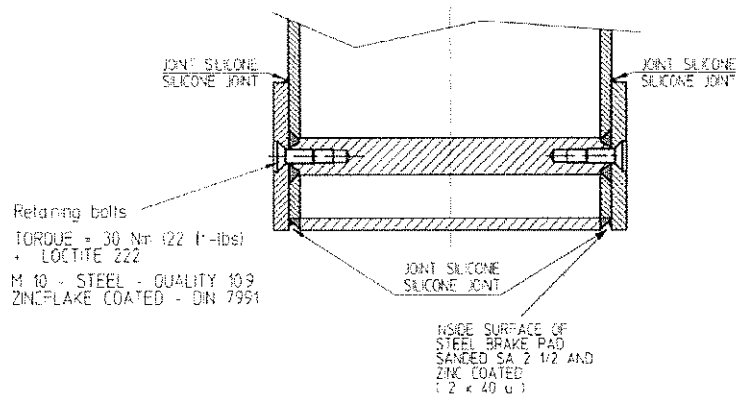

- Note:**
- the retaining bolts for steel brake pads are M10 hexagon socket countersunk head screws according to DIN 7991:
 - fully threaded
 - material: steel – quality 10.9
 - surface treatment: 3 zincflake coated (Dacromet)
 - recommended torque: 30 Nm (22 ft-lbs)
 - the contact surfaces between the steel brake pad and the beam must be clean and free of grease / oil
 - silicon joint must be applied after assembly.

Inverted Coaster BATMAN THE RIDE

Six Flags Great Adventure

LIST OF MANUFACTURER'S NOTICES

<u>Manufacturer's Notice #</u>	<u>Date</u>
1 / 97	September 11, 1997
2 / 97	November 14, 1997
1 / 98	January 15, 1998
2 / 98	November 6, 1998
1 / 99	January 11, 1999
2 / 99	October 14, 1999
1 / 00	January 5, 2000
1 / 02	February 11, 2002
2 / 03	January 17, 2003
4 / 03 a	July 7, 2003
3 / 04	April 5, 2004

BOLLIGER & MABILLARD

CONSULTING ENGINEERS INC.

SIX FLAGS GREAT ADVENTURE

Attn: Mr. Bob Hoban,
Vice President, Maintenance
Route 537

Jackson, NJ 08527, USA

September 11, 1997

Re: Inverted Coaster Batman The Ride

1/97

Dear Bob,

We experienced a faulty anti-return SPRAG on one coaster.

We kindly ask you to check that the anti-return SPRAG is operating correctly on your coaster.

We enclose a procedure for that inspection.

We draw your attention to the fact that the anti-return SPRAG is a major safety device. The ride shall not be operated with a faulty anti-return SPRAG.

We thank you for your help with this matter.

Sincerely,

Encl.

IMPORTANT MANUFACTURER'S NOTICE

Park: **Six Flags Great Adventure, Jackson**

Roller Coaster: **Inverted Coaster Batman The Ride**

We recommend to inspect the SPRAG anti-return as per the following procedure:

Daily inspection

- Listen to the SPRAG for abnormal noise. In case of an abnormal noise, inspect the SPRAG.
- When the train is stopped on the lift for the block check, check that the shock absorber and spring are compressed, indicating that the SPRAG is operating correctly.

Weekly inspection

- Push down on the torque arm, compressing the spring and shock absorber. Then attempt to lift the torque arm. It should not be possible.

September 11, 1997

BOLLIGER & MABILLARD

CONSULTING ENGINEERS INC.

SIX FLAGS GREAT ADVENTURE
Attn: Mr. Bob Hoban,
Vice President, Maintenance
Route 537

Jackson, NJ 08527, USA

November 14, 1997

Re: Inverted Coaster Batman The Ride

Dear Bob,

Please find hereenclosed

♦ **Manufacturer's notice # 2 / 97**

The purpose of this notice is to describe the recommended yearly inspection of the chain more precisely.

We recommend the inspection to be done in accordance with this notice at the end of each season.

We thank you in advance for your help with this matter.

Sincerely,

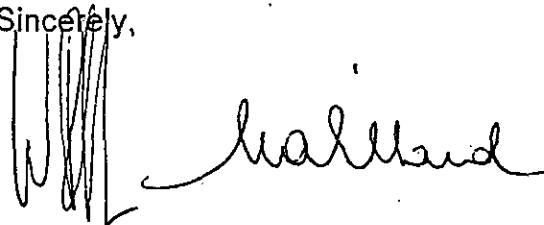

Encl.: ment.

IMPORTANT MANUFACTURER'S NOTICE

Park: **Six Flags Great Adventure, Jackson**

Roller Coaster: **Inverted Coaster Batman The Ride**

We recommend to inspect the chain at the end of each season as per the following procedure:

1. Terminology

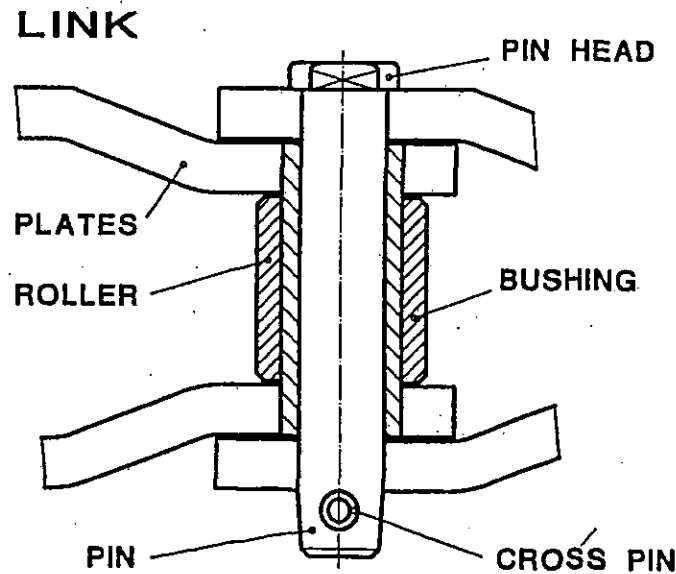

2. Inspection of the chain links

- Release the pretension of the chain by slightly lifting the counterweight.
- Check
 - a) that every link is freely articulated;
 - b) every roller is turning freely on the bushing.

3. Inspection of the alignment of the chain

- Inspect the alignment of the chain. The chain must not touch the steel walls of the chain troughs.

4. Inspection of the plastic guide

- Inspect the plastic guides for wear along the entire length of the lift. Replace the plastic guides if the wear exceeds 2 mm.

5. Protection

- Clean the chain troughs, protect the chain with thick oil to protect it from corrosion during the winter season.

November 14, 1997

BOLLIGER & MABILLARD

CONSULTING ENGINEERS INC.

SIX FLAGS GREAT ADVENTURE
Attn: Mr. Bob Hoban,
Vice President, Maintenance
Route 537

Jackson, NJ 08527, USA

January 15, 1998

Re: Inverted Coaster Batman The Ride

Dear Bob,

Please find hereenclosed

◆ **Manufacturer's notice # 1 / 98**

The purpose of this notice is to describe an additional recommended daily inspection of the boggies and the seat supports.

We recommend the inspection to be done in accordance with this notice.

Please don't hesitate to contact us should you have any question regarding this notice.

We thank you in advance for your help with this matter.

Sincerely,

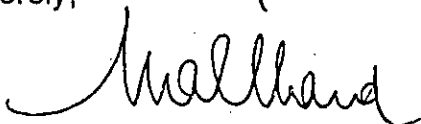

IMPORTANT MANUFACTURER'S NOTICE

Park: **Six Flags Great Adventure, Jackson**

Roller Coaster: **Inverted Coaster Batman The Ride**

1) We draw your attention to the fact that cracks were found on one Inverted Coaster on following components:

- Boggie
- Seat support

2) Accordingly, we ask you to carefully visually check daily:

⇒ **Boggie**

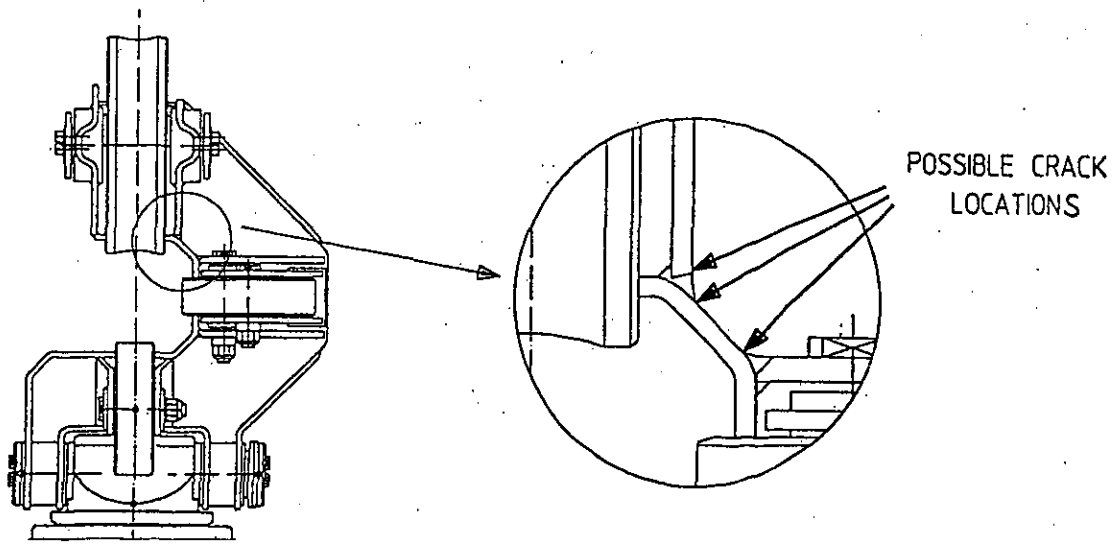

⇒ **Seat support**

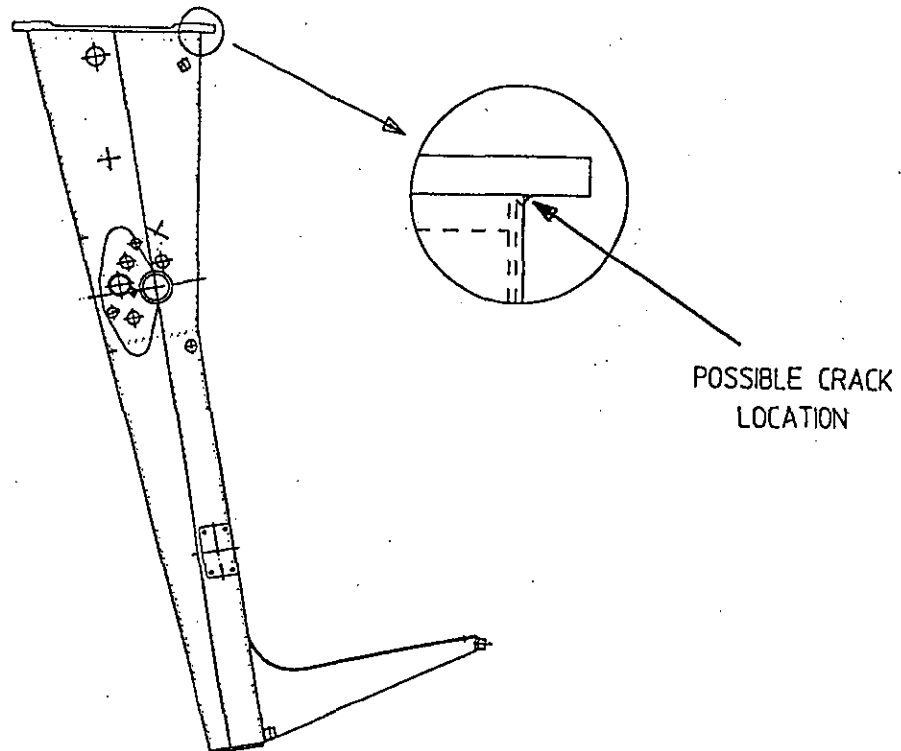

THIS INSPECTION SHALL BE DONE IN ADDITION TO THE DAILY INSPECTIONS DESCRIBED IN THE MAINTENANCE MANUAL.

3) Information to the manufacturer

We ask you to inform B & M of any crack you may discover.

4) Temporary repair procedure

- a) Remove the crack by grinding
- b) NDT inspection to make sure that the entire crack is removed
- c) Weld using a process adequate for ASTM A36 steel
- d) NDT inspection of the weld

BOLLIGER & MABILLARD

CONSULTING ENGINEERS INC.

SIX FLAGS GREAT ADVENTURE
Attn: Mr. Bob Hoban,
Vice President, Maintenance
Route 537

Jackson, NJ 08527, USA

O/ref.: W. Bolliger / cc

November 4, 1998

Re: Inverted Coaster Batman The Ride

Dear Bob,

Please find hereenclosed

◆ **Manufacturer's notice # 2 / 98**

The purpose of this notice is

- a) to make you aware of the importance of a change of the loudness of the above mentioned coasters;
- b) to clarify weekly inspection of the road wheels with regard to out-of-roundness;
- c) to emphasize the importance of the lubrication of the rails.

We hope that this information will be useful.

Sincerely,

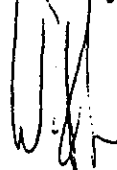

Encl.: ment.

IMPORTANT MANUFACTURER'S NOTICE

Park: **Six Flags Great Adventure, Jackson**

Roller Coaster: **Inverted Coaster Batman The Ride**

LOUDNESS OF THE RIDE / OUT-OF-ROUNDNESS OF THE WHEELS

1. Loudness of the ride

A change in the loudness of the ride indicates a problem which shall not be ignored.

First step is to investigate the wheels as indicated under item 3.

Other investigations may be necessary to find the source of the change of the loudness.

2. Motion of the wheels on the track

2.1 The complex three dimensional geometry of the rails requires two motions of the wheels:

- Rolling
- Sliding sidewise

2.2 In order to avoid damages to the wheels, the running surface of the track must be kept slightly greasy.

See item 2.4 herebelow.

2.3 Insufficient lubrication of the rail will cause uneven wear of the nylon rims:



2.4 The flat spots around the wheel will cause:

- ⇒ the ride to be louder;
- ⇒ vibration of the coaches and of the box beam.

SUCH VIBRATION, IF NOT CORRECTED, WILL CAUSE DAMAGES TO THE COACHES AND TRACK.

3. Inspection of the road wheels

Road wheels shall be inspected for out-of-roundness weekly and when the loudness of the ride may indicate a deterioration of the wheels.

Out-of-roundness can be felt with a finger or by measurement.

Out-of-roundness exceeding 0.2 mm (0.008 inch) requires remachining of the wheels. Remachining of the rims shall be done in accordance with B&M specifications.

4. Lubrication of the track and of the road wheels

(as indicated in the Maintenance Manual, item 1.7.4)

The running surface of the track (contact between rails and nylon wheels) and the outside surface of the rims must be kept slightly greasy. We recommend to apply on the track on all reachable and low areas a mixture of oil and wax-oil like CASTROL SAFETY-DRAW 722 X. Suggested mixture is:

- ◆ 2 parts of oil (standard motor oil)
- ◆ 1 part of CASTROL 722 X.

Frequency: We basically recommend to apply this mixture twice a week and after a heavy rain on the track and on the outside surface of the nylon tires.

This will considerably increase the life time of the wheels.

BOLLIGER & MABILLARD

CONSULTING ENGINEERS INC.

SIX FLAGS GREAT ADVENTURE
Attn: Mr. Bob Hoban,
Vice President of Maintenance
Route 537

Jackson, NJ 08527, USA

January 11, 1999

Re.: **Inverted Coaster Batman The Ride**

Dear Bob,

Please find hereenclosed

◆ **Manufacturer's notice # 1 / 99**

The purpose of this notice is to describe an additional recommended inspection of the connections "rail to flange".

We recommend the inspection to be done in accordance with this notice.

Please do not hesitate to contact us should you have any question regarding this notice.

We thank you in advance for your help with this matter.

Sincerely,

IMPORTANT MANUFACTURER'S NOTICE

Park: **Six Flags Great Adventure, Jackson**

Roller Coaster: **Inverted Coaster** **Batman The Ride**

- 1) We draw your attention to the fact that cracks were found at a limited number of connections "rail - flange" on four coasters.

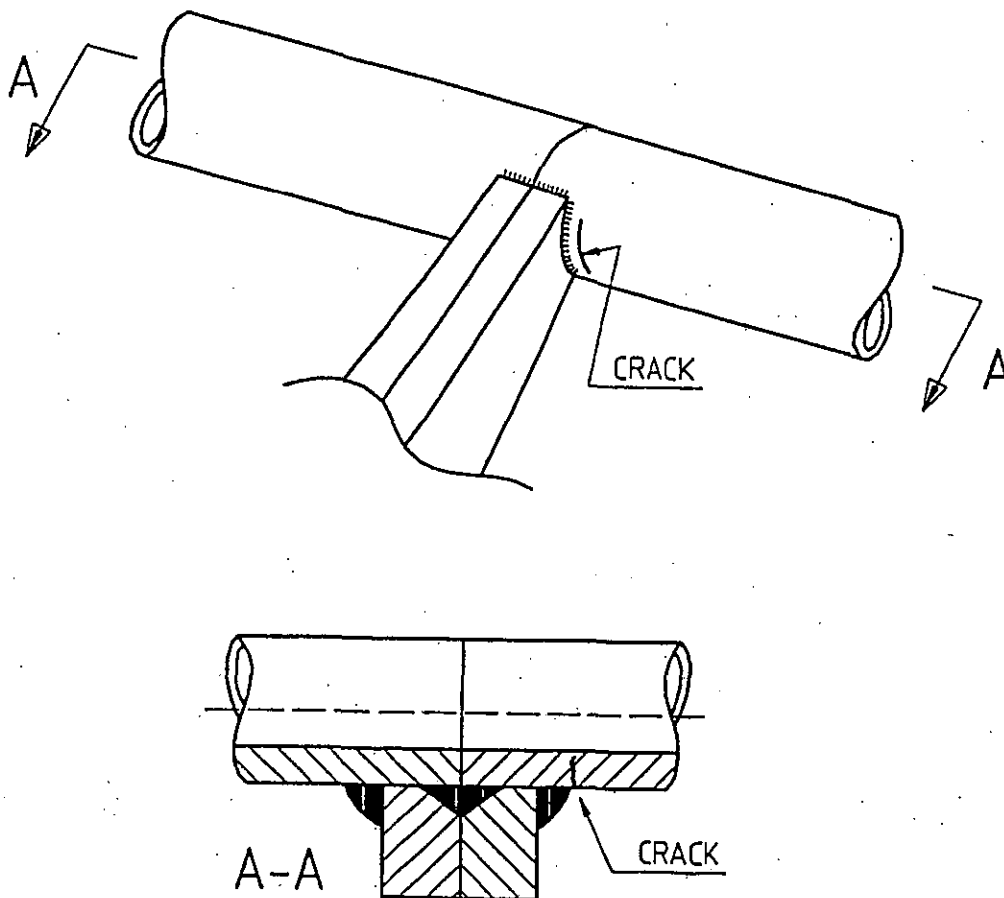

On three coasters, cracks were related to displacement of foundation.

- 2) Accordingly, we ask
- a) to carefully visually check any motion of the foundations while the train is operated.

At least two trained persons shall be used for that inspection:

- first inspector will check each foundation for possible motion
- second inspector will make sure that himself and the first inspector are out of reach of the moving train

Pathway, out of reach of a moving train, shall be carefully studied in order to avoid any accident.

- b) to carefully visually check the connections rail to flanges

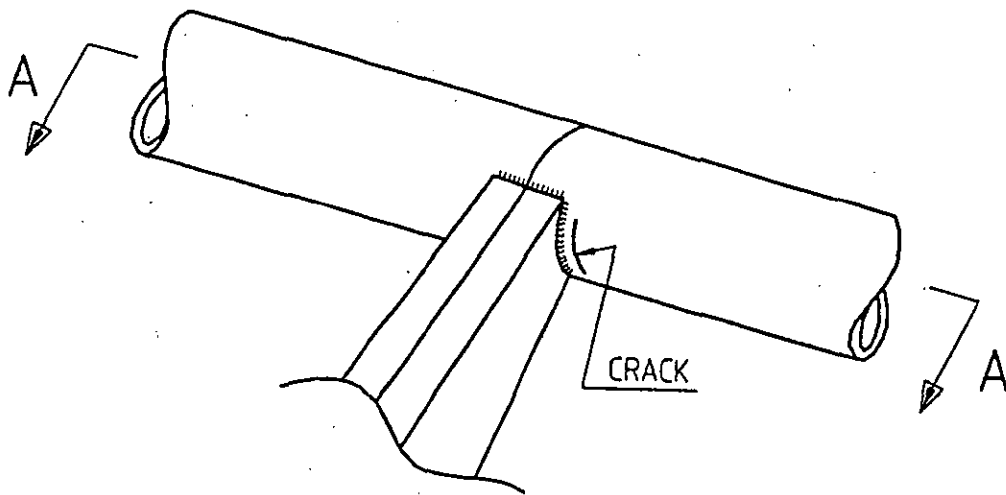

at following intervals:

- if no motion of the foundation is detected: every three months
- if a motion of the foundation is detected: every month

- 3) We further recommend to make a precise survey of the location of each track foundation every year, in order to ascertain that there is no permanent displacement of the foundation.

BOLLIGER & MABILLARD

CONSULTING ENGINEERS INC.

SIX FLAGS GREAT ADVENTURE
Attn: Mr. Robert J. Hoban,
Maintenance Vice President
Route 537
Jackson, NJ 08527, USA

O/ref.: C. Mabillard / me

October 14, 1999

Re.: Inverted Coaster Batman The Ride
Sitting Coaster Medusa

Dear Bob,

Please find hereenclosed

◆ Manufacturer's notice # 2 / 99

related to all types of B&M coasters.

We hope that this will not cause too much inconvenience and thank you in advance for your help.

Sincerely,

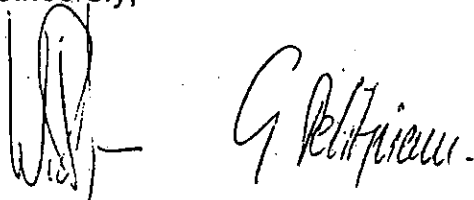
Handwritten signature of G. Peltier, consisting of a stylized 'G' followed by 'Peltier'.

Encl.: ment.

IMPORTANT MANUFACTURER'S NOTICE

2 / 99

Coasters: Inverted Coaster BATMAN THE RIDE
 Sitting Coaster MEDUSA

Components: Lift chain sprockets

We draw your attention to the fact that cracks were found on one of our coasters on the center hub weld of the lift chain sprockets:

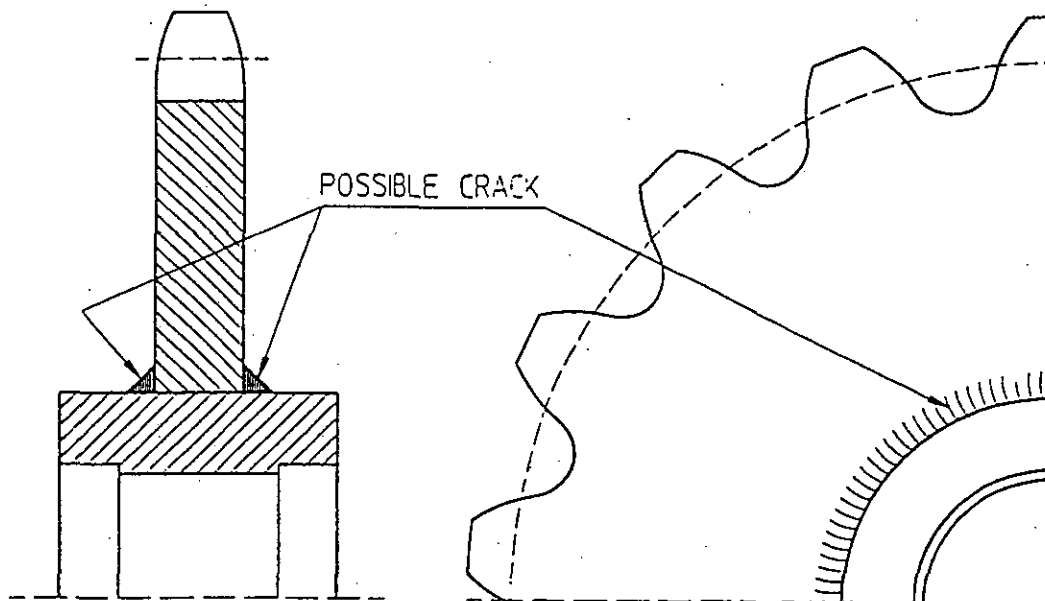

A total failure of such weld would cause severe damage at the lift chain.

Accordingly, we ask you to carefully visually check, every three months, the center hub welds of all lift chain sprockets, namely:

- 1. Drive sprocket
 - 2. Idler sprocket
 - 3. Tensionner sprocket
 - 4. Return sprocket
- } at the lift base
- at the lift top

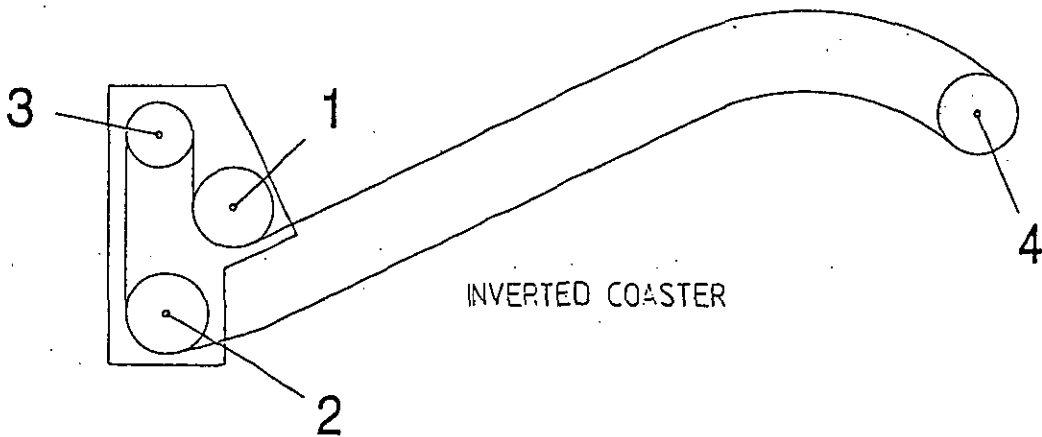
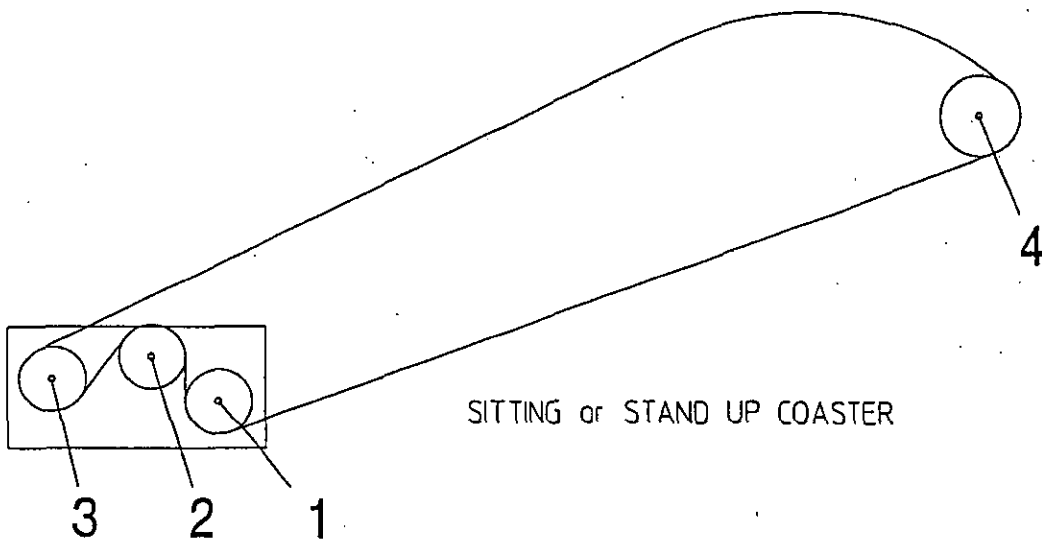

BOLLIGER & MABILLARD

CONSULTING ENGINEERS INC.

SIX FLAGS GREAT ADVENTURE

Attn. : Bob Hoban
Vice President of Maintenance
Route 537
Jackson, NJ 08527, USA

O/Ref. : W. Bolliger / G. Petitpierre / ru

January 5, 2000

Inverted Coaster Batman the Ride

Dear Bob,

Please find hereenclosed :

◆ **Manufacturer's notice # 1/00**

The purpose of this notice is to describe an additional inspection. We recommend the inspection to be done in accordance with this notice.

Please do not hesitate to contact us should you have any question regarding this notice.

We thank you in advance for your help with this matter.

Sincerely,



Encl. : ment

IMPORTANT MANUFACTURER'S NOTICE

Park: Six Flags Great Adventure, Jackson

Roller Coaster: Inverted Coaster Batman the Ride

Important: To perform this inspection, the bogie has to be dismantled from the pivot.

- 1) We draw your attention to the fact that cracks were found on the bogies of one Inverted Coaster. The location of those cracks is shown below :

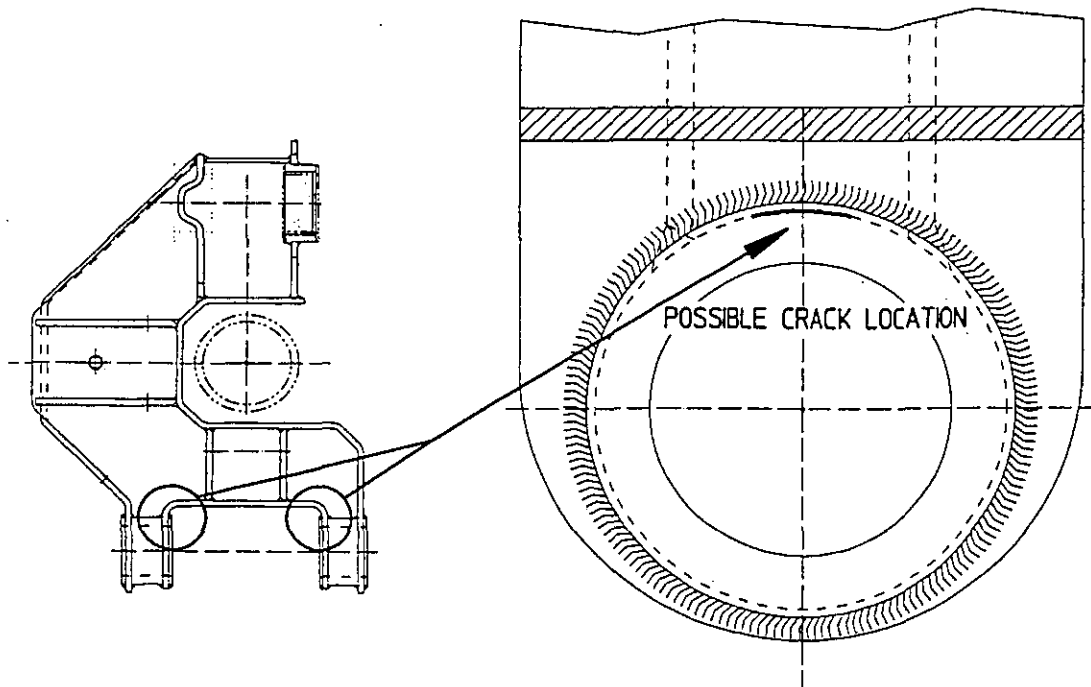

- 2) We recommend to inspect the possible crack location once a year with magnaflux or dye penetrant. It is necessary to dismantle the bogie to conduct this inspection.

BOLLIGER & MABILLARD

CONSULTING ENGINEERS INC.

SIX FLAGS GREAT ADVENTURE

Attn: Mr. Robert J. Hoban,
Maintenance Vice President
Route 537
Jackson, NJ 08527, USA

O/ref.: W. Bolliger / cc

February 11, 2002

Inverted Coaster BATMAN

Dear Bob,

We are pleased to send you hereenclosed :

◆ **Manufacturer's notice # 1/02**

The purpose of this notice is to describe an additional recommended inspection of the central beam of the coaches.

We recommend the inspection to be done immediately and then in accordance with this notice.

Please do not hesitate to contact us should you have any question regarding this notice.

We thank you in advance for your help with this matter.

Sincerely,

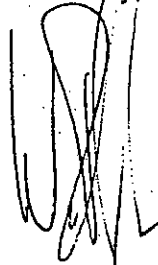

W. Bolliger

Encl.: ment.

IMPORTANT MANUFACTURER'S NOTICE

Park : **SIX FLAGS GREAT ADVENTURE**

Roller Coaster : **Inverted Coaster** **BATMAN**

- 1) We draw your attention to the fact that cracks were found at the extremity of the bolted connection of the central beam of the coaches on one B&M ride.

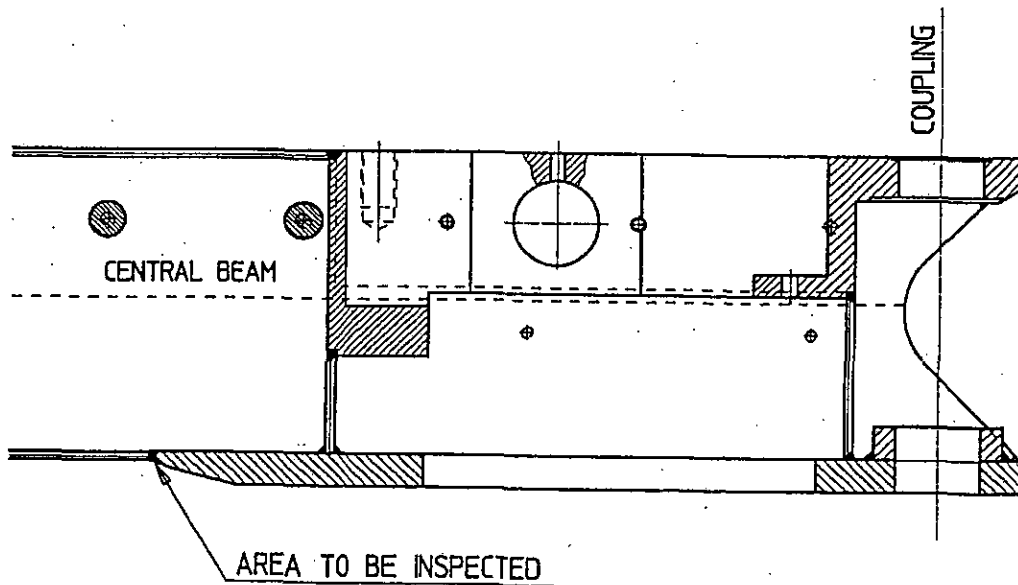

- 2) Accordingly, we ask you to inspect these connections as follows:
 - a) immediate visual inspection, then
 - b) weekly visual inspection.

- 3) If any crack is found, the crack needs to be repaired before being further operated.

Bolliger & Mabillard shall be immediately informed of any such crack.

BOLLIGER & MABILLARD

CONSULTING ENGINEERS INC.

Ch. des Dailles 31
1870 Monthey
Switzerland

Tel: +41 244 721 580
Fax +41 244 719 584
info@bmdesign.ch

SIX FLAGS GREAT ADVENTURE
Attn: Mr. Bob Hoban
Maintenance Vice President
Route 537
Jackson, NJ 08527, USA

O/ref.: G. Petitpierre / ru

January 17, 2003

Inverted Coaster BATMAN THE RIDE

Dear Bob,

We send you hereenclosed :

◆ **Manufacturer's notice # 2/03**

The purpose of this notice is to describe an additional recommended inspection of the bogies.

We recommend the inspection to be done immediately and then in accordance with this notice.

Please do not hesitate to contact us should you have any question regarding this notice.

We thank you in advance for your help with this matter.

Sincerely,



G. Petitpierre

IMPORTANT MANUFACTURER'S NOTICE

Park : **SIX FLAGS GREAT ADVENTURE**

Roller Coaster : **Inverted Coaster** **BATMAN THE RIDE**

- 1) We draw your attention to the fact that cracks were found on one Inverted Coaster on five bogies in the area shown below.

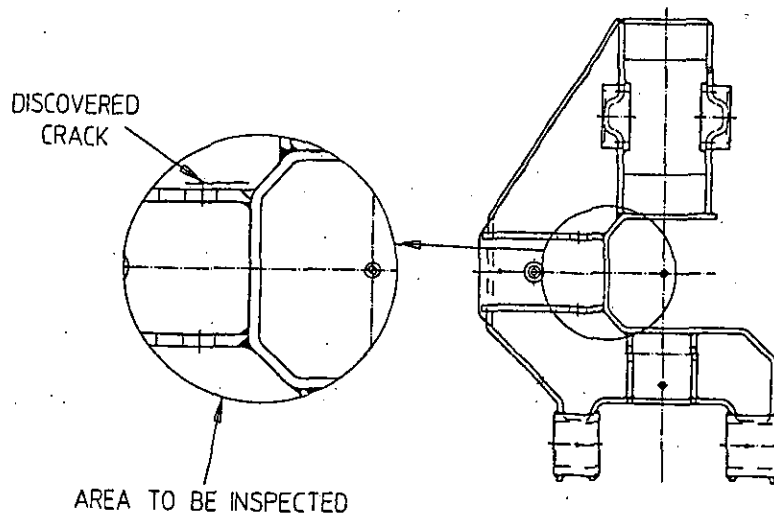

- 2) Accordingly we ask you :
- a) to inspect with Magnaflux the area shown above
- before starting the new season
 - at mid season.

It is necessary to dismantle the side wheels to carry out this inspection.

- b) to inspect visually once a week the area shown above. Dismantling of the side wheels is not necessary, except if visual inspection seem to indicate a crack.

THE ABOVE INSPECTION SHALL BE CARRIED OUT IN ADDITION TO THE INSPECTION DESCRIBED IN THE MAINTENANCE MANUAL.

- 3) Bolliger and Mabillard shall be informed of any crack. Ride shall not be operated if cracks are found in the bogies.

BOLLIGER & MABILLARD

CONSULTING ENGINEERS INC.

Ch. des Dailles 31
1870 Monthey
Switzerland

Tel. +41 244 721 580
Fax +41 244 719 584
info@bmdesign.ch

SIX FLAGS GREAT ADVENTURE

Attn: Mr. Larry Chickola,
Chief Corporate Engineer
Route 537
Jackson, NJ 08527, USA

O/ref. A. Beck / aj

July 7, 2003

Inverted Coaster **BATMAN THE RIDE**

Dear Larry,

Please find herewith:

◆ **Manufacturer's notice # 4 / 03 a**

The purpose of this notice is to describe an additional recommended inspection of the seat columns of the coaches.

We recommend the inspection to be done immediately and then in accordance with this notice.

Please do not hesitate to contact us, should you have any question regarding this notice.

We thank you in advance for your help with this matter.

Sincerely,

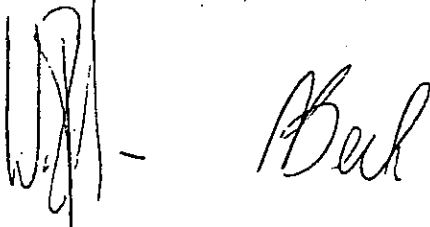
Handwritten signature of A. Beck, consisting of a stylized initial 'A' followed by the name 'Beck'.

Encl.: Ment.

IMPORTANT MANUFACTURER'S NOTICE

Park: **SIX FLAGS GREAT ADVENTURE**

Roller Coaster: **Inverted Coaster BATMAN THE RIDE**

- 1) We draw your attention to the fact that cracks were found in the weld shown below, on seat columns of one B&M ride.

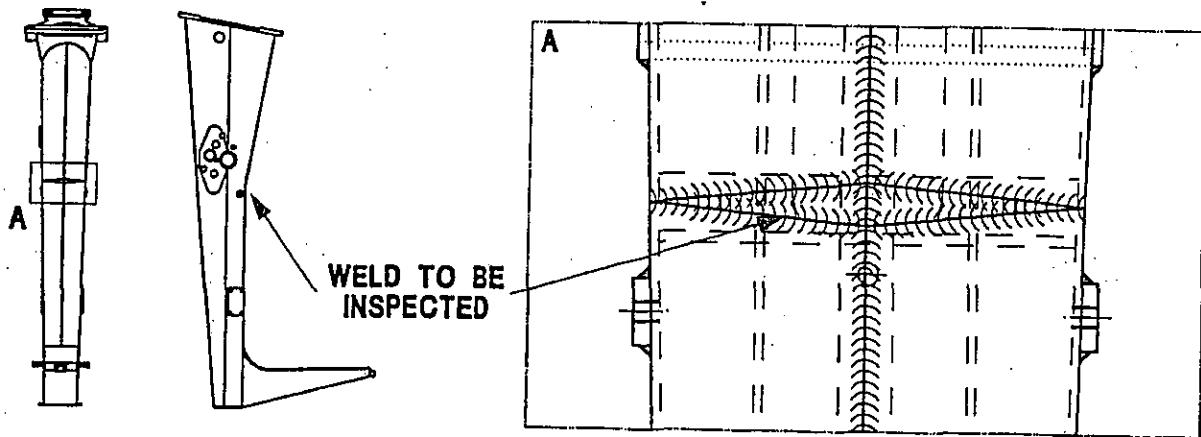

- 2) Accordingly, we ask you to inspect these connections as follows:
 - a) immediate visual inspection
 - b) magnetic particles inspection within 20 days
 - c) monthly visual inspection.

- 3) If any crack is found, no passenger shall be allowed on the seat where the crack was found before it is repaired.

Bolliger & Mabillard shall be informed of any such crack.

July 7, 2003

BOLLIGER & MABILLARD
CONSULTING ENGINEERS INC.

des Dailles 31
170 Monthey
Switzerland

Tel. +41 244 721 580
Fax +41 244 719 584
info@bmdesign.ch

SIX FLAGS GREAT ADVENTURE

Attn: Mr. Don Burkholder,
Director of Maintenance &
Construction

Route 537
Jackson, NJ 08527, USA

O/ref.: G. Petitpierre / E. Berra / ru

April 5, 2004

Inverted Coaster BATMAN THE RIDE

Dear Don,

We send you hereenclosed :

◆ **Manufacturer's notice # 3/04**

Purpose of this notice is to require an additional inspection of the vehicle central beam/coupling receiver.

Please do not hesitate to contact us should you have any question regarding this notice.

We thank you in advance for your help with this matter.

Sincerely,

G. Petitpierre *Eric*

Encl.: ment.

IMPORTANT MANUFACTURER'S NOTICE

Park : **SIX FLAGS GREAT ADVENTURE**

Roller Coaster : **Inverted Coaster Batman The Ride**

1. We draw your attention to the fact that one crack was found in the weld between the end plate of the central beam and the pipe of the coupling receiver on a B&M coaster.

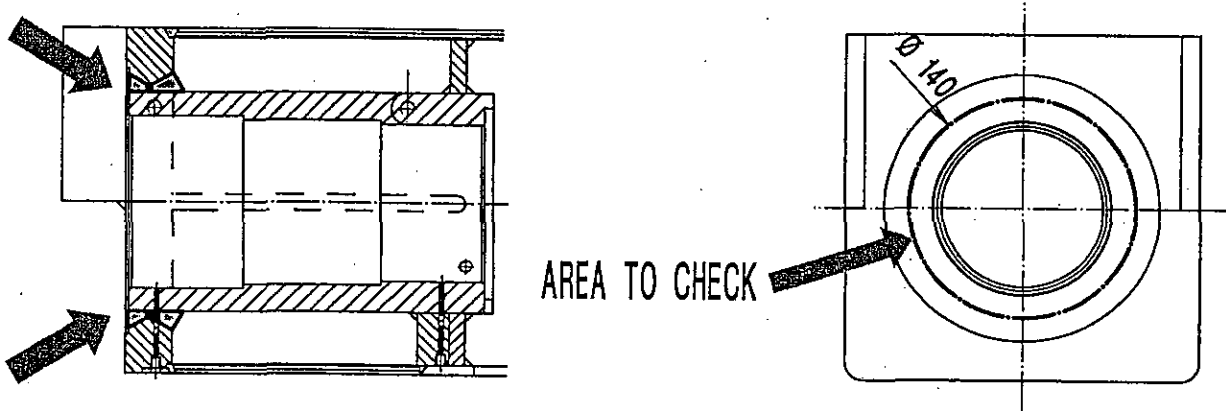

2. INSPECTION

2.1 GENERAL

THE AREA SHOWN ABOVE SHALL BE INSPECTED AT LEAST ONCE A YEAR AS FOLLOWS:

- a) dismantle the fork and the front thrust washer on each vehicle.
- b) magnetic particle inspection of the area shown above.

2.2 IMMEDIATE ADDITIONAL INSPECTION

- a) No immediate additional inspection is required for the Park who did carry out the inspection as indicated under paragraph 2.1 above within the last six months (e.g. inspection carried out during the annual maintenance as per the maintenance manual).
- b) For the Parks who did not carry out the inspection as indicated under paragraph 2.1 above within the last six months, an inspection in accordance with paragraph 2.1 above shall be carried out within 45 days.

3. INFORMATION TO THE MANUFACTURER

Bolliger & Mabillard shall be informed of any crack found. Vehicles presenting cracks shall not be operated.

A repair can be conducted according to the following instructions:

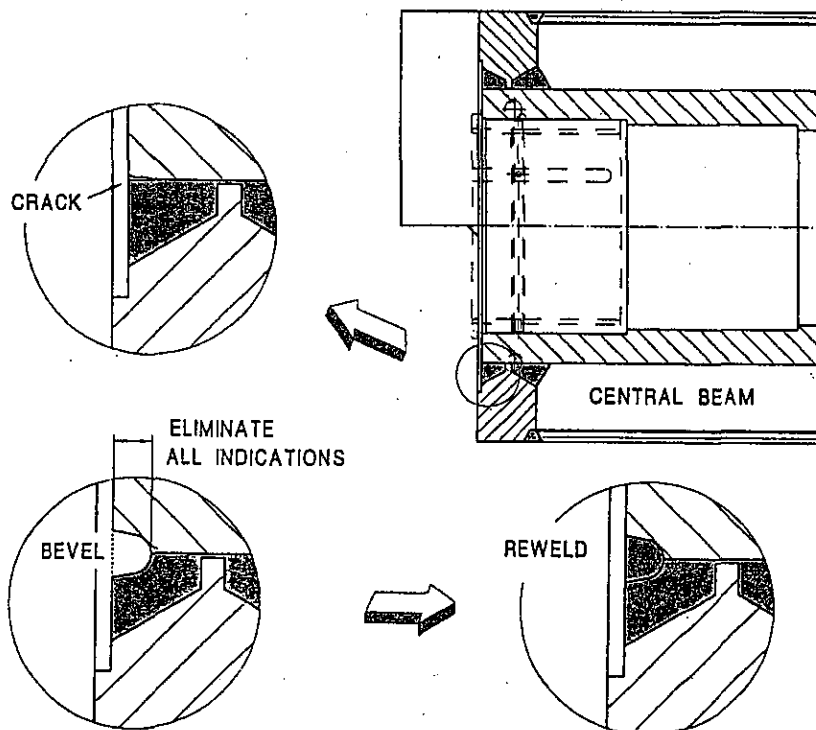

1. Eliminate the crack by grinding and prepare the bevel as shown.
2. Preheat at 180 - 200 F°
3. Reweld the root using TIG process.
4. Liquid penetrant test after the first pass.
5. Finish welding using SMAW or GMAW.
6. Final NDT check.
7. Grind the surface flush using a gauge.
8. Touch up paint.

SERVICE BULLETIN

Affected Park: Six Flags Great Adventure
Affected Ride: Inverted Coaster
Ride Name: BATMAN THE RIDE

Drawing No: IC-C33-014
Item No: 9

Abstract of Issue:
Inspection of the spline shafts of the shoulder harnesses
Item # 9 – drwg IC-C33-014

Reason for Release:

Machining marks have been discovered on a limited number of spline shafts. Such indications are not critical. It is however recommended to replace spline shafts which show such marks or other signs of wear.

Action to be taken:

Inspection (magnetic particle or dye penetrant) of spline shafts shall be carried out during the next annual inspection, but not later than March 31, 2006. Spline shafts showing marks or signs of wear shall be replaced.

Completion:

During the next annual inspection, but not later than March 31, 2006.

Detail of Issue:

Typical picture of machining mark:

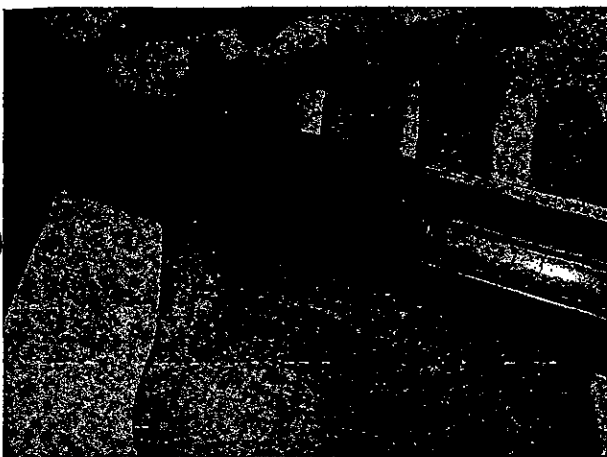

BOLLIGER & MABILLARD
CONSULTING ENGINEERS INC.

Ch. des Dailles 31
1870 Monthey
Switzerland

Tel. +41 244 721 580
Fax +41 244 719 584
info@bmdesign.ch

Bulletin No.:	13
Release Date:	July 6, 2005
Effective Date:	July 6, 2005
Supersedes:	Notice 1/97
Issued by:	A. Beck
Checked by:	G. Petitpierre / E. Berra
Page:	1 of 2

NOTIFICATION

Affected Park: Six Flags Great Adventure
Affected Ride: Inverted Coaster
Ride Name: BATMAN THE RIDE

Item: Lift driving unit one way clutch (Sprag Clutch)

Abstract of Issue:

This notification clarifies the lubrication, the inspection and the installation of the lift drive unit one way clutch hereafter called Sprag Clutch.

Reason for Release:

Clarification of the lubrication, the inspection and the installation of the lift drive unit one way clutch hereafter called Sprag Clutch.

Action to be taken:

Lubricate and inspect the Sprag Clutch as indicated.

Detail of Issue:

GREASE LUBRICATION

1. The clutch is factory packed with Fuchs Renolit MP2 grease. Only other recommended grease mentioned on the table below may be used. **THE USE OF LUBRICANTS OTHER THAN THOSE RECOMMENDED CAN CAUSE IMPROPER SPRAG ENGAGEMENT AND SUBSEQUENT FAILURE OF THE UNIT.**
2. Grease the sprag clutch every 3 months. Wipe fittings clean and pump new grease into all fittings until it flows past labyrinth seals on both sides of unit.

BOLLIGER & MABILLARD

CONSULTING ENGINEERS INC.

Ch. des Dailles 31
1870 Monthey
Switzerland
Tel. +41 244 721 580
Fax +41 244 719 584
info@bmdesign.ch

Bulletin No.:	13
Release Date:	July 6, 2005
Effective Date:	July 6, 2005
Supersedes:	Notice 1/97
Issued by:	A. Beck
Checked by:	G. Petitpierre / E. Berra
Page:	2 of 2

Affected Park:
Six Flags Great Adventure

Affected Ride: Inverted Coaster

Ride Name: Batman The Ride

Detail of Issue continued:

GREASE

TEMPERATURE RANGE	RECOMMENDATION
-7°C TO + 65°C	FUCHS RENOLIT MP2 (Original) MOBIL GREASE MP2 MOBIL MOBILUX 2 SHELL ALBIDA R2 ESSO BEACON 2

INSPECTION OF THE SPRAG CLUTCH

Daily Inspection

Listen to the sprag for abnormal noise. In case of abnormal noise:

- inspect the sprag to find the cause of the noise
- carry out the inspection as specified for the weekly inspection

Weekly Inspection

To check the sprag clutch efficiency, stop the train on the lift so that no anti-rollback dogs are in contact with the toothed rack (the whole train load is then supported by the sprag clutch). It may be necessary to stop the train several times on the lift to get that result.

INSTALLATION (Clutch replacement)

1. Before mounting on a shaft, check for damage and dimensional accuracy.
2. Check that free direction of rotation is correct.
3. Offer unit to shaft and apply pressure to end face of inner race only.

High pressure applied to the outer race could cause damage to the bearings and premature failure of the unit.

4. Secure unit axially by use of retaining plate.
5. Reconnect the torque arm